



# THE ABC OF BPHEs

CHALLENGE EFFICIENCY

**SUVER**  
A DOVER COMPANY

# OUR BPHE CONCEPT

The compact Brazen Plate Heat Exchanger (BPHE) is constructed as a plate package of corrugated channel plates with a filler material between each plate. During the vacuum-brazing process, the filler material forms a brazed joint at every contact point between the plates, creating complex channels. The BPHE allows media at different temperatures to come into close proximity, separated only by channel plates that enable heat from one media to be transferred to the other with very high efficiency. The concept is similar to the older plate and frame technology, but without the gaskets and frame parts.

## Simple, flexible, cost-effective

The channel plates form separate circuits for each media. The number, type and configuration of the channel plates are easy to vary to provide the thermal characteristics required.

In a one-pass configuration, the two flows are continuous through each channel plate. In a two-pass configuration, the two flows are redirected by special channel plates to give the equivalent of two units connected in series. In addition to one- and two-pass configurations, we offer a variety of other executions and customized solutions. The flows inside a heat exchanger can be arranged differently to fulfill different

purposes. In our BPHEs, counter-current flow is more common because it increases efficiency. However, our BPHEs also employ co-current flow where necessary in applications such as flooded evaporators.

## Easy to install

Compared with shell-and-tube models of the same capacity, our BPHEs are as much as 90% smaller by weight and volume. The BPHE is not only easier to transport and handle, but its size means it also offers greater system design freedom. Further-more, connections are available in a wide range of industry standards.

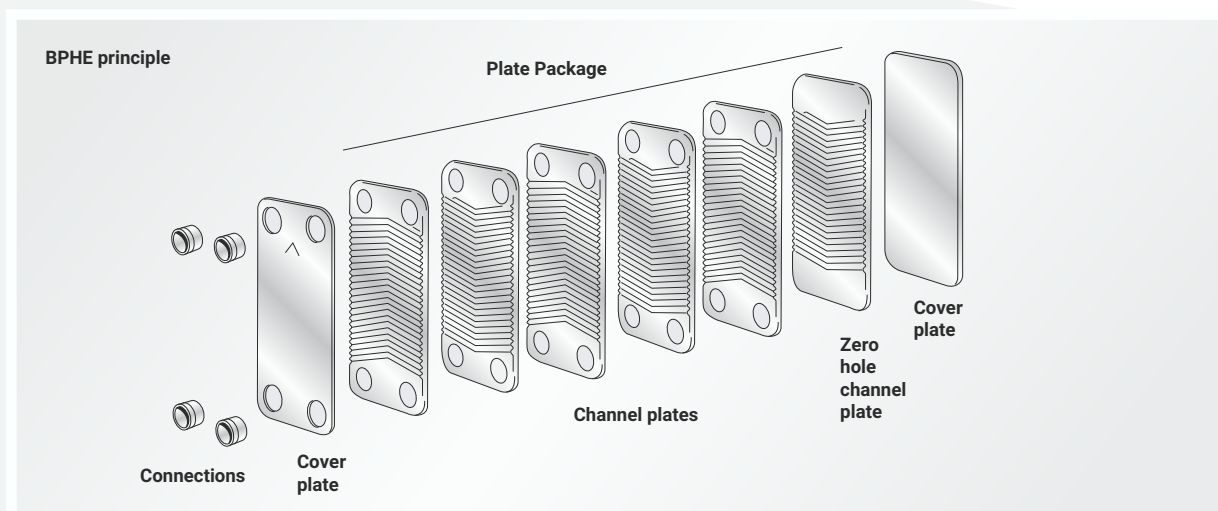

# OUR BENEFITS

Our experience and expertise have been gained all over the world across a wide range of applications in many different climates. We aim to maximize the performance and at the same time minimize the amount of material used. This has environmental benefits, keeps costs down and reduces exposure when material prices increase. Other benefits of our BPHEs include:

- Tailored: Optimized and customized
- Performance: Reliable, energy-efficient and cost-effective
- Economical: Optimal material usage
- Versatile: Cover a wide range of cooling and heating capacities
- Competitive: Save space compared with S&T heat exchangers; withstand high temperature and pressure (no gaskets), unlike PHE heat exchangers, and have minimal weight
- Turbulent: Resist scaling and fouling; effective self-cleaning

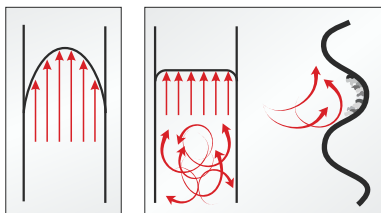

- Innovative: Patented solutions, e.g. true dual, double-wall and asymmetric BPHEs
- Tested: Pressure- and leak-tested. All widely recognized pressure vessel codes available, e.g. PED, KHK and UL.
- Responsive: Small holdup volume and lower refrigerant charge
- Standards: Comply with standards such as ISO 9001 (quality) and ISO 14001 (environmental)

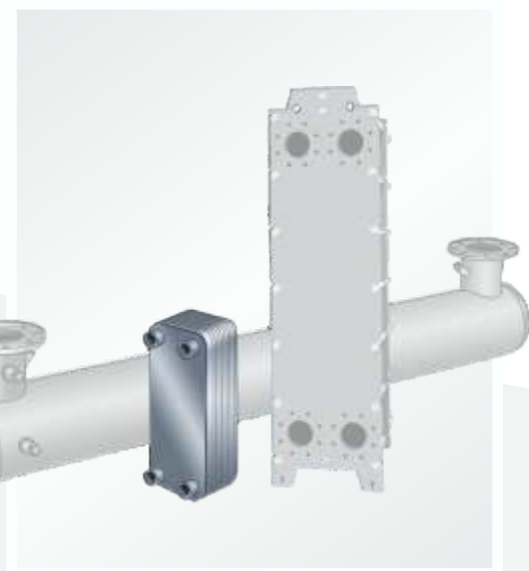

# OUR BPHEs ARE SUPERIOR

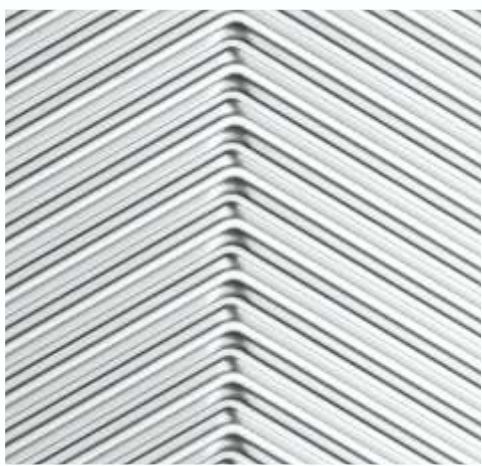

## Products

- We have the widest range of BPHEs in the world.

## High-quality products and services

- We have ISO 9001 and ISO 14001 approval.
- We use SPC (Statistical Process Control) in all steps of our production.
- We offer full traceability using the unique serial number on each unit, which enables us to trace the unit to its raw material, press line and tools, furnace and pressure test equipment.
- We thoroughly investigate claims, and the result whether it is a line or field failure is always taken seriously. The results of claims are monitored and followed up statistically to help us refine our products and processes to avoid them.

## Largest production capacity in the world

- Our six factories around the world make it safe to be one of our customers.
- We use state-of-the-art, fully automated and continuous cut and press lines in our production.
- We have the highest number of vacuum brazing furnaces among BPHE manufacturers, which enables us to grow with our customers.

## Assured longest service life

- The raw materials used in our products meet the highest requirements.
- We carry out periodic burst testing of products taken from production to ensure we meet our customers' highest demands.
- Every product we deliver is verified by pressure-testing to a minimum of 1.5 times its working pressure in each circuit, and then tested for leaks with helium to ensure detection of even the smallest leakage. We can detect leakages equivalent to 2.8 g of R22 at 10 bar pressure over a year. All pressure tests are carried out with compressed air to avoid any contamination of the product.
- We assure the quality of the vacuum brazing process by maintaining sufficient material thickness after pressing.

## Leading R&D

- We have used Computational Fluid Dynamics (CFD) since the mid 90's, and we apply the knowledge collected in this tool in all new product development to optimize performance and material utilization.
- We produce tools in-house, because we know that a few hundredths of a millimeter makes a difference to the product's strength.
- We have our own laboratory for one- and two-phase applications.
- We have several patented designs and solutions such as true dual, double wall and air dryer.
- Our dedicated innovation team constantly pushes the limit.



## Top performance you can trust

- We verify all new products in our heat transfer laboratory before they are released to the market.
- Our calculation software is continuously updated with the latest laboratory results to ensure it corresponds to our best current knowledge.
- Our BPHEs deliver documented and reliable performance in both laminar and turbulent flow regions.
- Our Corner Passage Pattern utilizes the area around the heat exchanger ports for heat transfer.
- We use thinner channel plate material to improve the performance/cost ratio with the same or better ability to withstand temperature and pressure. Today we offer standard, medium, high and ultra-high pressure ratings on our products (30, 42, 45 and 140 bar).



## Application and product knowledge

- Our highly skilled staff help customers select the right model for their individual needs.
- We offer unique expertise acquired across a wide range of different applications.



## Availability

- Our SWEP Software Package (SSP), available from [www.swep.net](http://www.swep.net), makes it easy to select the right model.
- Most items are available from our centralized warehouses for fast delivery.
- We offer customized products and connections through our fast and flexible product configurator.
- We provide automatically generated 3D drawings for customers to base their designs upon.



# AIR CONDITIONING APPLICATIONS

Our BPHEs efficiently provide cooling water for air conditioning. This makes it possible to maintain a constant comfortable temperature in offices, hospitals, homes and other locations.

## Chillers

In a chiller, a refrigerant cycle is used indirectly to cool homes or commercial areas via the energy-absorbing effect of the evaporator. We have a wide range of BPHEs that work efficiently as dedicated evaporators in both air- and water-cooled chillers. We also offer reliable BPHEs as condensers to reject the heat in water-cooled chillers. Our BPHEs also have proven excellent performance as economizers and desuperheaters, improving system efficiency.

## Absorption chillers

Our BPHEs improve the efficiency of absorption chillers, where as subcoolers and preheaters they can optimize the system. Absorption chillers are an alternative when electricity is limited or heat is abundant. Instead of using the conventional refrigerant cycle, high-temperature heat is used as the main energy source. The refrigerant is usually water and the absorbent is a lithium bromide solution. Our BPHEs have a proven ability to withstand lithium bromide, which is corrosive, thanks to their high-quality materials and our excellent system expertise.



# HEATING APPLICATIONS



Examples of applications in the heating area include heat pumps, gas-fired boilers and district heating substations. The effectiveness and compactness of our BPHEs are ideal for these applications, and the overall size of the system can often be reduced considerably using a BPHE solution.

## Boilers

Our BPHEs are used in residential gas-fired boilers to provide hot tap water. We have a dedicated product range with small, compact and efficient BPHEs that deliver high comfort and efficiency in your system. The SWEP software package, SSP, helps you to select the best BPHE solution for your boiler.

## Heat pumps

Our BPHEs work efficiently with other heat pump components to upgrade renewable energy absorbed from the ground or ambient air to provide hot water for space heating and tap water. The versatility of our BPHEs enables them to be used in reversible systems, where they also can deliver cooling. Our BPHEs handle tight temperature approaches, which decreases the work input needed in the compressor and hence increases the COP of your system.

## District heating

District heating systems distribute heat produced centrally to consumers for space heating and hot tap water. Our BPHEs operate efficiently and reliably in district heating substations to transfer heat from the network to the domestic heating circuit.

## Solar

With their small CO<sub>2</sub> footprint, our BPHEs are ideal for smart solar heating systems. Solar heating has the obvious environmental and economic advantages that the energy supplied is free and renewable. Careful design incorporating our BPHEs delivers reliability, efficiency and minimal running costs.

# INDUSTRIAL APPLICATIONS

Our BPHEs are robust, compact, cost-effective and reliable over long periods with minimal maintenance – all vital qualities in industrial applications. We bring immense international experience to this area, which includes cooling for oil, laser and electronic systems. Our BPHEs are also suitable for fuel oil heating and highly efficient cogeneration (CHP) systems. The BPHE's flexible design and the ability to customize both the plate and brazing materials frequently mean unbeatable performance compared with conventional heat exchangers.

## Oil cooling

Our wide range of BPHEs covers the needs of several different types of oil cooling e.g. hydraulic, engine and transmission oil cooling. The reliability and compactness of our BPHEs are highly valued in oil cooling applications, where space for the heat exchanger is often limited and access for maintenance is restricted.

## Air dryers for air compressors

A common problem in compressed air systems is condensation, which can cause corrosion and considerable damage to the equipment using the air. We provide the solution, with air dryers that prevent the condensation of water in pneumatic systems. We have both conventional air dryers and the innovative ADWIS, the air dryer with integrated separator. With our BPHE solution, the air is cooled with a refrigerant, the water vapor is condensed and the moisture is removed all in one smart, compact and cost-effective unit.

## Laser and electronics cooling

Laser and electronic equipment is often cooled using purified (e.g. deionized) water as a coolant in order to protect sensitive components. Water in this condition can have undesirable effects on cooling systems, but we have a reliable solution. Our nickel-brazed BPHEs meet the strict demands imposed on materials by deionized water.





# REFRIGERATION APPLICATIONS



Our wide range of BPHEs covers several heat transfer functions in refrigeration applications, where they help keep things cool efficiently and with consideration to the environment. Refrigeration applications often involve high pressure, so the robustness of our BPHEs makes them an excellent choice. Our BPHEs are designed to distribute the refrigerant uniformly over the plate. This gives optimal utilization of the heat-exchanging surface, and creates an extremely compact and cost-effective solution.

## Transport

Our BPHEs are used in container chillers and freezers used to transport fruit, fish and other temperature-sensitive goods. Our BPHEs are commonly used as economizers in these systems, where they boost efficiency.



## Supermarkets

In supermarkets, cooling is needed at medium temperature for display cases and at low temperature for deep freezers. Our BPHEs fulfill several functions in supermarket refrigeration systems, where they work safely and reliably as evaporators, condensers, economizers and desuperheaters.



# OPTIMIZED FOR NEW REFRIGERANTS

## Environmentally friendly

Older refrigerants are being displaced by modern alternatives on environmental grounds. Today's preferred refrigerants, such as R410A, R134a and CO<sub>2</sub>, are helping countries comply with their Kyoto targets, but they have been difficult to use efficiently. We now offer BPHEs optimized for these refrigerants.

## R410A

Our P-type is optimized for the refrigerant R410A, which is regarded as a long-term global HCFC replacement. R410A achieves the same amount of cooling with less refrigerant, enabling the design of more compact systems. The P-type consist several single- and dual-circuit BPHEs working in a wide capacity range from 20 kW to 400 kW.



## R134a

Our S-range is dedicated to applications using the refrigerant R134a. The S-type includes the DS500, which is the largest true dual evaporator and represents a major step forward in BPHE capacity for R134a applications. The DS500 can handle capacities up to 600 kW and competes vigorously in a market previously dominated by shell-and-tube heat exchangers.

## CO<sub>2</sub>

CO<sub>2</sub> has great potential as a refrigerant, but its operating conditions are very demanding. We have BPHEs that performs efficiently with CO<sub>2</sub> in chiller systems with capacities of 350 kW and more. For transcritical systems, our B16DW is approved for operation at up to 140 bar.

## OUR PATTERNS

### Corner passage pattern

Our CPP (Corner Passage Pattern) technology is based on a uniquely designed channel plate. It directs the cooling media around the port in a special way, opening up a larger area for heat transfer in the port area. This significantly improves heat transfer and hence efficiency.

### Asymmetric flow

Our innovative and patented new asymmetrical plate pattern enables BPHEs to transfer more heat using less

material (kW/kg basis). Apart from the environmental gains, this also means that systems can now be smaller than competing solutions with comparable performance.

### The X-plate

Another high-tech innovation is our new X-plate design. This offers not only higher performance but also increased mechanical strength. Brought together in the X-plate, these two characteristics enable us to use even less material to even greater effect.



# PROFESSIONAL SUPPORT



## SSP – the soft way to get hard facts

You can easily identify the optimal BPHE solution for your application using our dimensioning software, SSP, which handles Single phase, Condenser and Evaporator calculations. Its advanced calculation models use your input data to calculate which BPHE will be most efficient for your application. The software is available for download free of charge (see [www.swep.net](http://www.swep.net)), and is easy to use thanks to its intuitive user interface.

## Quick guides

The market's most comprehensive handbooks on heat transfer are available to download free of charge from [www.swep.net](http://www.swep.net) or on CD-ROM from your local SWEP representative. These three digital handbooks give you first-class technical information on Refrigerant, Heating and Industrial applications: everything from

the basics of heat transfer to discussions of specific applications.

## Quick selector

The Quick selector (available to use free of charge on [www.swep.net](http://www.swep.net)) helps you quickly select the BPHE you need. You can choose from a wide variety of applications, from a small boiler to a 250 kW district heating installation.

## Cross-reference guide

If you are already using a heat exchanger from another company, the Cross-reference guide on [www.swep.net](http://www.swep.net) will make it easy to change to our BPHEs. Simply choose your existing manufacturer, model and number of plates, and the guide will suggest a suitable replacement from our range.

# MANUFACTURING

For us, the keys to world-class manufacturing are competence and efficiency. Over the years, we have acquired enormous competence in every aspect of BPHE manufacturing. This is reflected in our factories in China, Sweden, Switzerland, the United States, Malaysia and Slovakia.

We use Statistical Process Control (SPC) through-out manufacturing to analyze and evaluate the mass of production data and to identify deviations from control values. Alongside SPC, we use Six Sigma to control defects and Lean manufacturing to minimize waste and optimize work flows.

## Simulation

Simulation reinforces R&D creativity and is one of the most important stages in the development of new and existing BPHEs. It accelerates time-to-volume and improves the functionality of new products.

## Tooling

We precision-mill our own press tools in a totally integrated CAD/CAM process. This assures quality and availability at a vital stage in production, and guarantees consistency from series to series.

## Laboratory

We have our own fully developed R&D laboratory, which has facilities for testing the heat transfer capacity of single-phase and two-phase applications, flow distribution, strength, mechanical and thermal fatigue performance, etc.

## Materials

We have developed far-reaching specifications, and buy only from certified suppliers. This ensures that our products have a long and reliable service life backed up by the traceability demanded by many third-party approvals. Manufacturing is available in AISI-316, AISI-304 and SMO-254.

## Pressing

We produce channel plates on automatic integrated press lines that guarantee consistently high quality. This precise and carefully supervised process ensures cost-effective manufacturing and maximal efficiency for each of our BPHEs.

## Brazing

Meticulous brazing is the key to leak-free, corrosion-resistant heat exchangers. We have developed specific brazing programs, with precisely adapted heating and cooling cycles, for every combination of materials and size of heat exchanger. The most common filler material is copper, but nickel is also available.

## Testing

We leak- and pressure-test all heat exchangers produced, regardless of the model, size and type of connection. Heat exchangers are normally pressure-tested at 1.5 times the maximum working pressure.

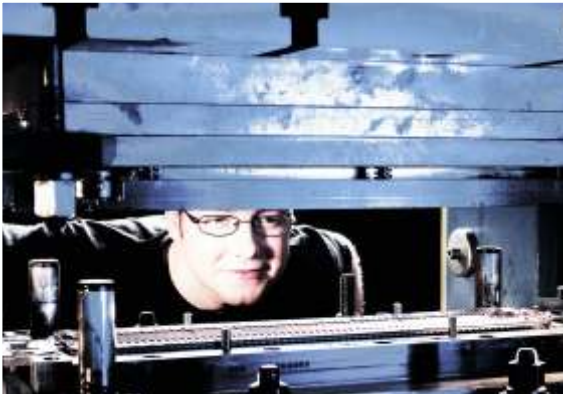

# A BPHE TYPE FOR EVERY NEED

The flexibility of our BPHEs makes them an excellent choice for many applications. The wide range of plate sizes, plate pattern combinations and connections enables a virtually unlimited number of combinations. You should be able to find a solution for your application among the models below.



## B-type

The B-type is our original BPHE. Its unique plate geometry, modular design and economical long manufacturing runs mean the product is easy to customize for many different applications.



## V-type

The V-type has been developed from the original B-type to achieve optimized performance as evaporators over a very wide capacity range. The refrigerant inlet has special technology to distribute the refrigerant evenly in each channel.



## P-type

The P-type evaporator has been developed from the V-type to optimize performance with the refrigerant R410A. The P-type is used as an evaporator in heat pump and chiller applications over a wide range of capacities.



## S-type

The S-type evaporator has been developed from the V-type to optimize performance with the refrigerant R134a. The S-type is used as an evaporator in heat pump and chiller applications.



## VH-type – high-performance evaporator

The VH-type has been developed from the V-type for improved performance with the refrigerant R407C in a high efficiency range. The VH-type can be used as an evaporator in chiller and heat pump applications.



## QA-type

The QA-type evaporator is optimized for R407C/R410A in heat pump applications in the heat flux range 2-4 kW/m<sup>2</sup>. The QA-type features a special injection system that ensures perfect distribution of the refrigerant into the evaporator. This minimizes the heat transfer surface used for superheating of the refrigerant whilst maintaining stable operating conditions.



## QB-type

The QB-type evaporator is optimized for R407C/R410A in heat pump applications in the heat flux range 4-6 kW/m<sup>2</sup>. The QB-type features a special injection system which ensures perfect distribution of the refrigerant into the evaporator. This minimizes the heat transfer surface used for superheating of the refrigerant whilst maintaining stable operating conditions.



### DB-type

Our patented true dual-circuit product puts the secondary circuit in contact with two primary circuits. Even if one primary circuit is shut off, the secondary circuit remains in contact with a primary circuit. These advantages make the DB-type the natural choice for flexible chillers, climate control and high-precision systems for food cooling cabinets in supermarkets.



### DV-type

Our patented true dual-circuit product puts the secondary circuit in contact with two primary circuits. Even if one primary circuit is shut off, the secondary circuit remains in contact with a primary circuit. The DV-type is optimized for evaporation, with innovative technology to distribute the refrigerant evenly in the heat exchanger.



### DP-type

The DP-type evaporator is also based on our true dual-circuit concept, and is optimized for the refrigerant R410A. Applications include flexible chillers, climate control and high-precision food cooling cabinets in supermarkets.



### DS-type

The DS-type evaporator is also based on our true dual-circuit concept, and is optimized for the refrigerant R134a. Applications include flexible chillers, climate control and high-precision food cooling cabinets in supermarkets.

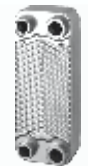

### E-type

The E-type is the most efficient BPHE on the market today, with almost all the material contributing to the heat transfer process. The E-type has been developed for low-pressure boiler applications (water to water) and moderate temperatures.



### BDW-type

The Double Wall concept is designed for applications requiring high thermal efficiency and no risk of internal leakage between the two fluids, such as in the food and pharmaceutical industries. In the unlikely event of a leak, water seeps out between the vented double walls to the atmosphere, giving a visual indication of a fault.



### ADWIS – Air Dryer With Integrated Separator

We have achieved breakthrough compactness with the ADWIS, which is one of the smallest air dryers on the market. The ADWIS combines two BPHEs (a refrigerated heat exchanger and a recovery unit) sandwiching an integrated separator in a modular design. This highly cost-effective solution offers stable high performance, convenient drainage and simple insulation.



### M-type (Minex)

The M-type is a hybrid PHE (plate and frame heat exchanger) sealed by gaskets instead of brazing material. It is a small unit, so it does not need the typical support frame used for traditional PHEs. Like our BPHEs, the Minex is available in various combinations of materials.

# DENOMINATION

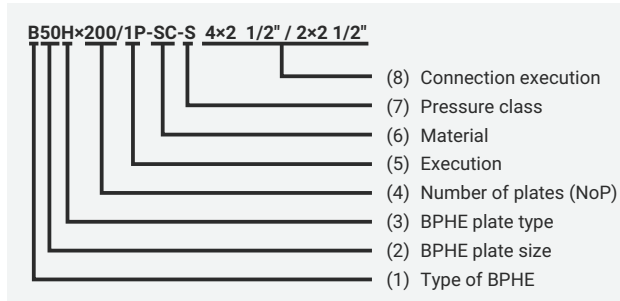

A BPHE should in principle always be denominated as shown in the figure. The different groups (1) to (8) are explained to the left.

# INSTALLATION

## General (one phase)

The BPHE shall be connected so that the fluids flow counter currently to maximize performance of the BPHE. Piping to the BPHE shall be installed so that no pulsations or pressure peaks (from e.g. pump, valves, compressor, etc.) are transferred to the BPHE. If the media contains particles larger than 1 mm it is recommended that a filter of mesh size 16-20 is installed in front of the BPHE.

## Evaporator

The BPHE shall be installed standing with the refrigerant inlet connected to the lower port (F3 or P3) and with the refrigerant outlet at the upper port (F1 or P1).

## Condenser

The BPHE shall be installed standing with the refrigerant inlet connected to the upper port (F1 or P1) and with the refrigerant outlet at the lower port (F3 or P3).

# EXECUTION EXAMPLES

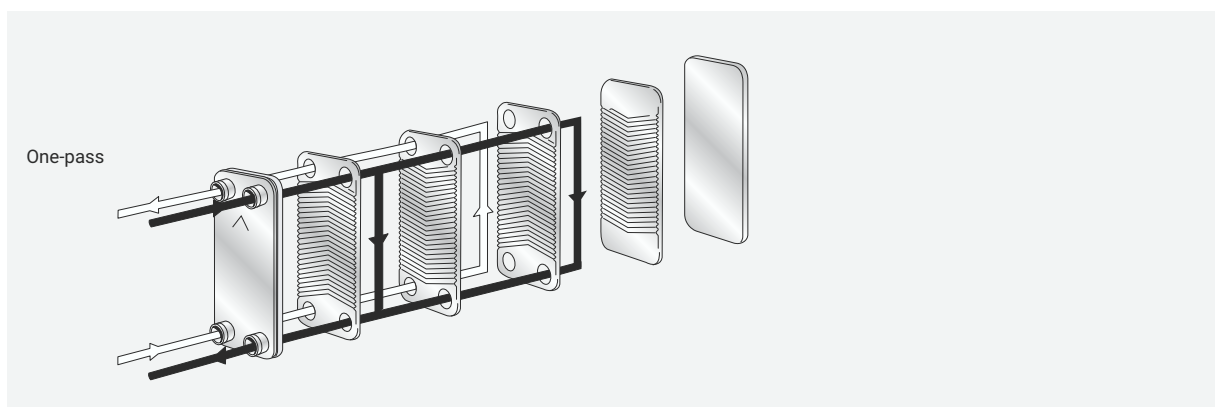



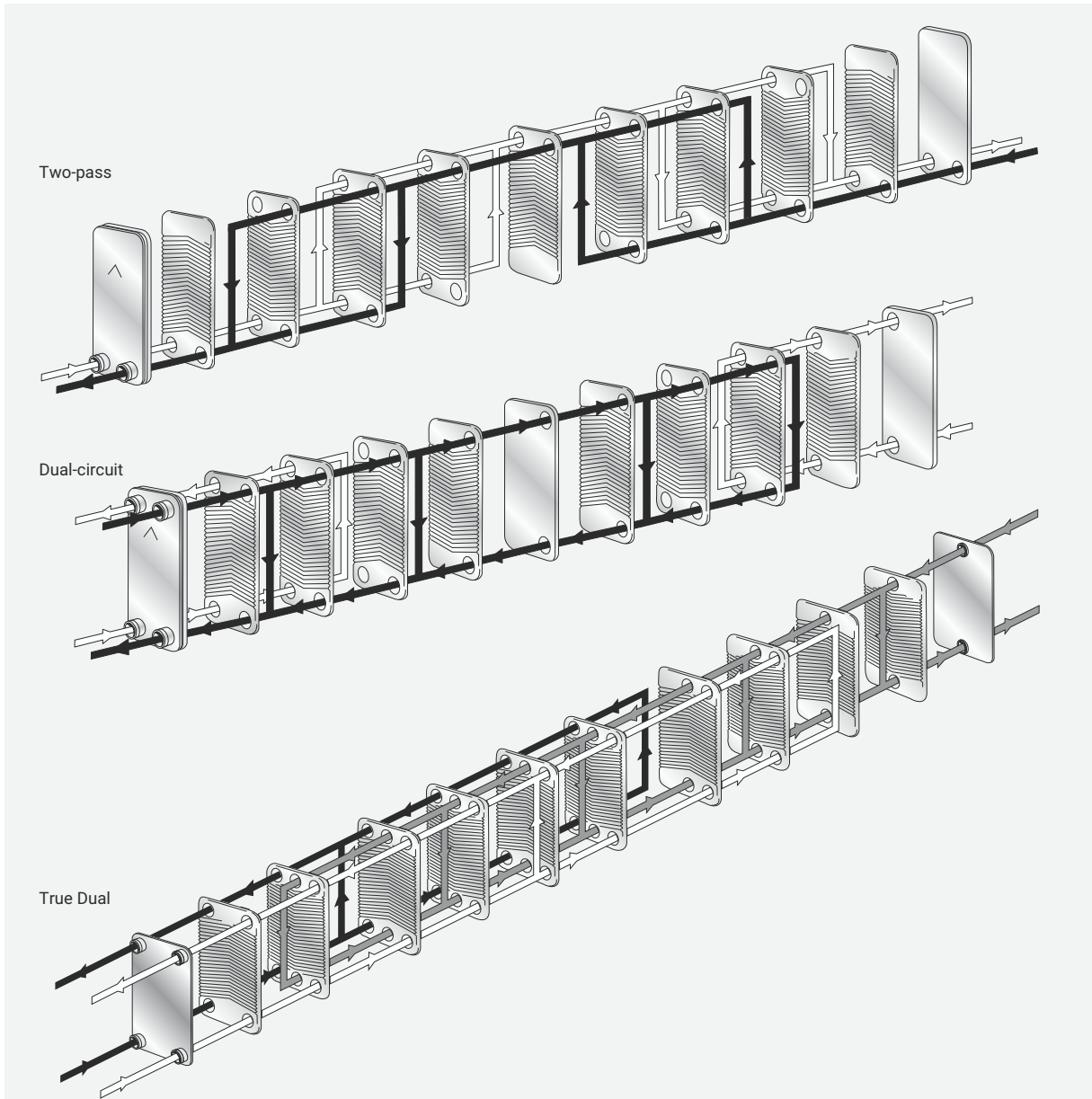

# STANDARD CONNECTION TYPES

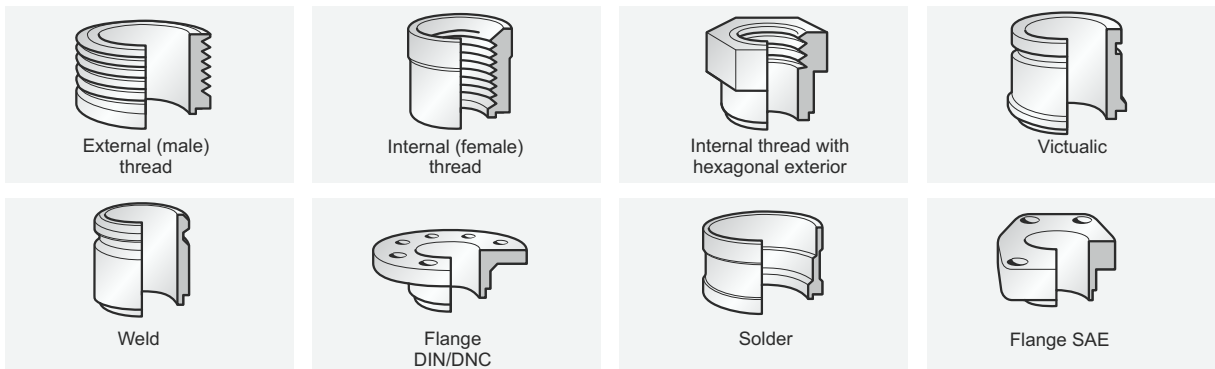

# ACCESSORIES

Our accessories meet the same high standards as our BPHEs because they are produced to our specification by rigorously selected manufacturers. The high-quality materials are carefully chosen for compatibility, while the accurate dimensions save you time and money on installation. With our accessories you have the assurance that everything will fit and perform the way the design engineers intended. The comprehensive range includes flanges, stud bolts, support legs and insulation, as well as CIP (Cleaning in place) kits that allow a BPHE to be cleaned quickly and economically without removing it from the system.

## Support equipment

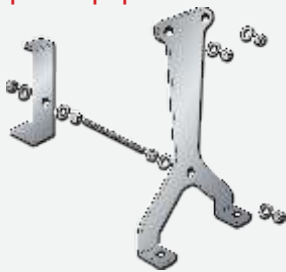

When you need mechanical support for one of our heat exchangers, we have tailor-made support legs and wall mounting kits available. Each kit comes correctly sized and complete with all fixings, ready for use on site. For the speed and convenience of first-time assembly, our support equipment cannot be beaten.

## Insulation



Insulation for heat exchangers can improve the performance of the BPHE depending on the internal and external temperatures. It also reduces energy losses in the system, protects the units from freezing and external corrosion and finally ensures that the ambient environment is protected.

## Counter connections



Counter connections have been developed to fit our BPHE range perfectly, and are available for most DN/DNC flanges and many weld and solder sizes.

## CIP Cleaning unit



Flows in BPHEs are normally highly turbulent, which means the channels are self-cleaning. However, in some applications the fouling tendency can be very high, e.g. when using extremely hard water at high temperatures. In such cases it is always possible to clean the heat exchanger by circulating a cleaning liquid (CIP - Cleaning In Place). Use a tank with weak acid (5% phosphoric acid or, if the heat exchanger is cleaned frequently, 5% oxalic acid). Pump the cleaning liquid through the heat exchanger.

# DESIGN DATA SHEET

Company:	E-mail:
Name:	Phone:

General one phase application - Heat load: \_\_\_\_\_ kW

Side 1	Media:			Side 2	Media:		
	Temperature in:		°C		Temperature in:		°C
	Temperature out:		°C		Temperature out:		°C
	Flow rate:		l/min		Flow rate:		l/min
	Max pressure drop:		kPa		Max pressure drop:		kPa

Evaporator and economizer applications - Heat load: \_\_\_\_\_ kW

Side 1 (evaporated media)	Media:			Side 2 (media to be cooled)	Media:		
	Evap temp. (dew point):		°C		Temperature in:		°C
	Superheating:		K		Temperature out:		°C
	Flow rate:		kg/h		Flow rate:		l/min
				Max pressure drop: _____ kPa			

Condenser and desuperheater applications - Heat load: \_\_\_\_\_ kW

Side 1 (condensing media)	Media:			Side 2 (media to be heated)	Media:		
	Hot gas temperature in:		°C		Temperature in:		°C
	Cond. temperature:		°C		Temperature out:		°C
	Sub cooling:		K		Flow rate:		l/min
	Flow rate:		kg/h		Max pressure drop:		kPa

Additional information:

Send the Design sheet to your local SWEP contact or e-mail it to: [info@swep.net](mailto:info@swep.net)

SWEP is the world's leading supplier of compact brazed plate heat exchangers (BPHEs). These products are used where heat needs to be transferred efficiently in air conditioning, refrigeration, heating and industrial applications. SWEP is close to its customers, with representation in more than 50 countries and its own dedicated sales force in more than 20 countries. Highly efficient production units in Sweden, Switzerland, the USA, Malaysia, Slovakia and China enable SWEP to serve customers all over the world. SWEP is part of the global Dover Corporation, which is a multi-billion-dollar, NYSE-traded, diversified manufacturer of a wide range of proprietary products and components for industrial and commercial use.